

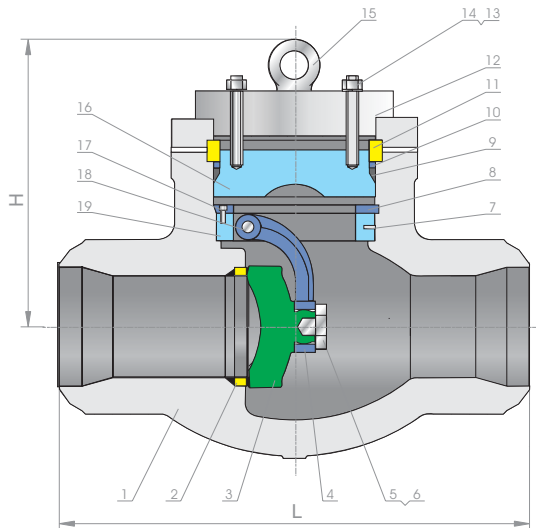

Cast Steel Pressure Seal Check Valves

Class 900/1500/2500

Pressure seal cover, Swing type disc.



For 4" and smaller

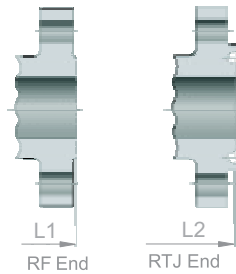
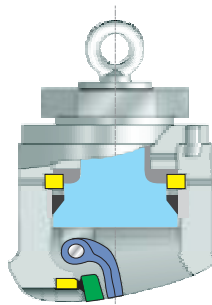

Features

- End to end dimension and face to face dimension : ASME B16.10
- Flange dimension : ASME B16.5
- Shell wall thickness: API 600
- B.W. end to ASME B16.25

Parts List

No:	Parts	Material
1	Body	ASTM A216 Gr.WCB
2	Seat ring	ASTM A105+STL No.6
3	Disc	ASTM A216 Gr.WCB+13Cr
4	Hinge	ASTM A216 Gr.WCB
5	Disc cover	ASTM A276 410
6	Screw	ASTM A276 410
7	Split pin	ASTM A276 410
8	Clamp ring	ASTMA105
9	Sealing ring	ASTMA182 F304
10	Spacer ring	ASTMA182 F6a
11	Segment ring	ASTMA182 F6a
12	Cover	ASTM A216 Gr.WCB
13	Cover bolt	ASTM A193 Gr.B7
14	Cover nut	ASTM A194 Gr.2H
15	Eye bolt	C.S.
16	Bonnet	ASTM A216 Gr.WCB
17	Bolt	S.S.
18	Pin	ASTM A276 410
19	Hinge block	ASTM A216 Gr.WCB

Dimensions and Weights

	Valve Size	in. mm	2	2 1/2	3	4	6	8	10	12	14	16
			50	65	80	100	150	200	250	300	350	400
900lb	L (BW)	in. mm	8.5 216	10 254	12 305	14 356	20 508	26 660	31 787	36 914	39 991	43 1092
	L1 (RF)	in. mm	14.5 368	16.5 419	15 381	18 457	24 610	29 737	33 838	38 965	40.5 1029	44.5 1130
	L2 (RTJ)	in. mm	14.62 371	16.62 422	15.12 384	18.12 460	24.12 613	29.12 740	33.12 841	38.12 968	40.88 1038	44.88 1140
	H	in. mm	7.4 188	8.27 210	8.27 210	8.5 216	14.5 368	20.12 511	24.17 614	27.76 705	28.98 736	29.76 756
	WT (kg)	RF BW	48 33	63 44	60 42	122 76	254 177	511 383	938 703	1448 1128	1723 1353	1832 1463
	1500lb	L (BW)	in. mm	8.5 216	10 254	12 305	16 406	22 559	28 711	34 864	39 991	42 1067
L1 (RF)		in. mm	14.5 368	16.5 419	18.5 470	21.5 546	27.75 705	32.75 832	39 991	44.5 1130	49.5 1257	54.5 1384
L2 (RTJ)		in. mm	14.62 371	16.62 422	18.62 473	21.62 549	28 711	33.13 841	39.38 1000	45.12 1146	50.25 1276	55.38 1407
H		in. mm	10.43 265	10.43 265	10.63 270	14.57 370	18.7 475	22.44 570	24.8 630	30.31 770	31.3 795	32.44 824
WT (kg)		RF BW	58 40	73 51	71 69	128 84	332 228	588 458	1023 713	1528 1148	1852 1388	2058 1542
2500lb		L (BW)	in. mm	11 279	13 330	14.5 368	18 457	24 610	30 762	36 914	41 1041	—
	L1 (RF)	in. mm	17.75 451	20 508	22.75 578	26.5 673	36 914	40.25 1022	50 1270	56 1422	—	—
	L2 (RTJ)	in. mm	17.87 454	20.25 514	23 584	26.88 683	36.5 927	40.87 1038	50.88 1292	56.88 1445	—	—
	H	in. mm	11.02 280	12 305	12.2 310	14.57 370	19.1 485	21.42 544	27.95 710	31.5 800	—	—
	WT (kg)	RF BW	86 52	113 88	133 93	213 158	548 383	988 638	1598 1198	2298 1723	—	—