



Forged Steel Pressure Seal Y-Pattern Globe Valves

Class 900/1500/2500

Construction Features

Pressure-seal bonnet
Socket welding ends
Rising stem
Integral HF seat

Standards

Socket welding ends: ASME B16.11
Butt-welding ends: ASME B16.25
Basic design: ASME B16.34 、 API602、 BS 5352
Inspection and test: API 598

Parts List

No.	Part Name	Material
1	Body	ASTM A105N/Stellite Overlay
2	Disc	ASTM A276 420
3	Stem	ASTM A182 F6a
4	Bonnet	ASTM A105N
5	Seal Ring	Soft Iron
6	Yoke	ASTM A105N
7	Packing Washer	ASTM A276 410
8	Packing	Graphite
9	Nut	ASTM A108 1030
10	Gland	ASTM A276 410
11	Gland Flange	ASTM A105N
12	Eyebolt Nut	ASTM A194 Gr.2H
13	Eyebolt	ASTM A276 410
14	Eye Pin	ASTM A276 410
15	Hand Wheel	Malleable Iron
16	H.W. Lock Nut	ASTM A108 1020
17	Washer	ASTM A276 410
18	Nameplate	Aluminum
19	Bolt	ASTM A108 1020
20	Stem Nut	Aluminum Bronze

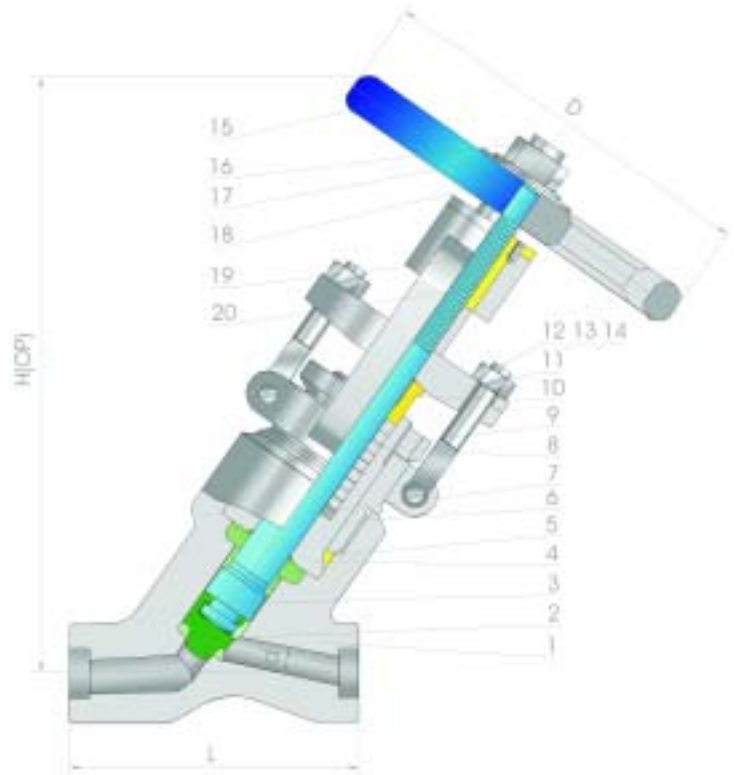

- Body material available in F304、F316、F304L、F316L、F11、F22、F5

Dimensions & Weights

Size(in.)	Dim.(mm)					Wt.(Kg)	
	Conv.	d	L		H	D	900lb/1500lb
900lb/1500lb			2500lb				
1/2	10	140	186	333	180	11.2	12.3
3/4	13	140	186	333	180	10.5	11.6
1	17	140	186	333	200	10.1	10.8
1 1/4	23	178	232	406	200	21.0	28.0
1 1/2	30	178	232	406	250	19.6	26.4
2	38	216	279	524	300	40.4	43.8