



Forged Steel Pressure Seal Globe Valves

Class 900/1500/2500

Construction Features

- Pressure-seal bonnet
- Socket welding ends and butt-welding ends
- Rising stem
- Integral HF seat

Standards

- Socket welding ends: ASME B16.11
- Butt-welding ends: ASME B16.25
- Basic design: ASME B16.34、API 602、BS 5352
- Inspection and test: API 598



Butt-welding ends (BW)

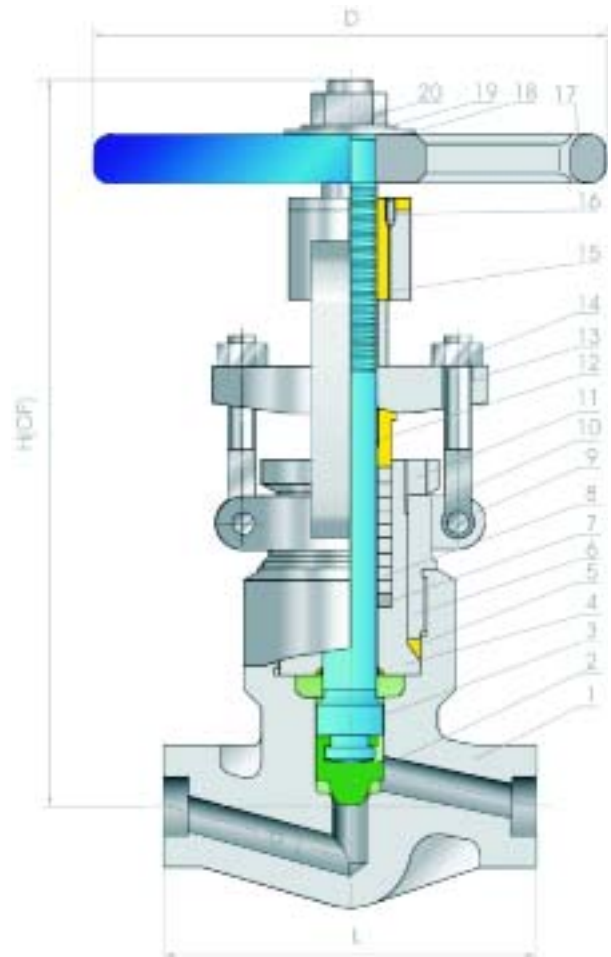

Parts List

| No. | Part Name | Material |
|-----|----------------|-----------------------------|
| 1 | Body | ASTM A105N/Stellite Overlay |
| 2 | Disc | ASTM A276 420 |
| 3 | Stem | ASTM A182 F6a |
| 4 | Bonnet | ASTM A105N |
| 5 | Seal Ring | Soft Iron |
| 6 | Yoke | ASTM A105N |
| 7 | Packing Washer | ASTM A276 410 |
| 8 | Packing | Graphite |
| 9 | Eye Pin | ASTM A276 410 |
| 10 | Eyebolt | ASTM A193 Gr.B7 |
| 11 | Nut | ASTM A108 1030 |
| 12 | Gland | ASTM A276 410 |
| 13 | Gland Flange | ASTM A105N |
| 14 | Eye Nut | ASTM A194 Gr.2H |
| 15 | Stem Nut | Aluminum Bronze |
| 16 | Bolt | ASTM A108 1020 |
| 17 | Handwheel | Malleable Iron |
| 18 | Nameplate | Aluminum |
| 19 | Washer | ASTM A276 420 |
| 20 | H.W. Lock Nut | ASTM A108 1020 |

- Body material available in F304、F316、F304L、F316L、F11、F22、F5

Dimensions & Weights (SW)

| Size(in.) | Dim.(mm) | | | | Wt.(Kg) | | |
|-----------|----------|--------------|--------|-----|---------|--------------|--------|
| | d | L | | H | D | 900lb/1500lb | 2500lb |
| Conv. | | 900lb/1500lb | 2500lb | | | | |
| 1/2 | 10 | 140 | 186 | 333 | 180 | 11.2 | 12.3 |
| 3/4 | 13 | 140 | 186 | 333 | 180 | 10.5 | 11.6 |
| 1 | 17 | 140 | 186 | 333 | 180 | 10.1 | 10.8 |
| 1 1/4 | 23 | 178 | 232 | 408 | 200 | 21.0 | 26.4 |
| 1 1/2 | 30 | 178 | 232 | 408 | 250 | 22.4 | 28.7 |
| 2 | 38 | 216 | 279 | 524 | 300 | 40.4 | 43.8 |