



Forged Steel Pressure Seal Gate Valves

Class 900/1500/ 2500

Parts List

No.	Parts	Material
1	Body	ASTM A105N
2	Seat Ring	A276-410/Stellite Overlay
3	Wedge	ASTM A276 420
4	Stem	ASTM A182 F6a
5	Bonnet	ASTM A105N
6	Seal Ring	Soft Iron
7	Yoke	ASTM A105N
8	Packing Washer	ASTM A276 410
9	Packing	Graphite
10	Eye Pin	ASTM A276 410
11	Eyebolt	ASTM A276 410
12	Nut	ASTM A108 1030
13	Gland	ASTM A276 410
14	Gland Flange	ASTM A105N
15	Eye Nut	ASTM A194 Gr.2H
16	Stem Nut	Aluminum Bronze
17	Handwheel	Malleable Iron
18	Nameplate	Aluminum
19	H.W. Lock Nut	ASTM A108 1020
20	Bolt	ASTM A108 1020

Construction Features

- Pressure-seal bonnet
- Socket welding ends and butt-welding ends
- Rising stem
- Rolled-in seat ring

Standards

- Socket welding ends: ASME B16.11
- Butt-welding ends: ASME B16.25
- Basic design: ASME B16.34 and API 602
- Inspection and test: API 598

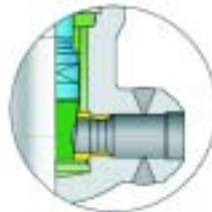

Butt-Welding Ends (BW)

- Body material available in F304, F316, F304L, F316L, LF2, F11, F22, F5

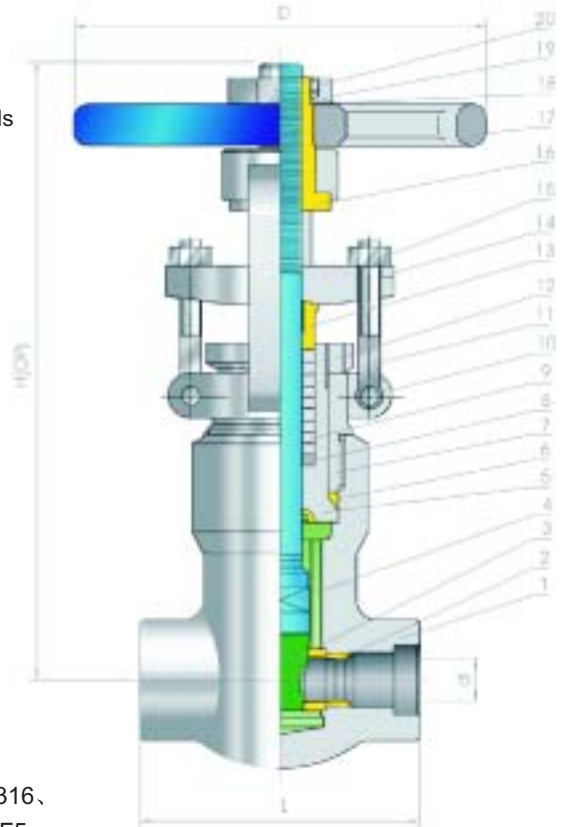

Dimensions & Weights (SW)

Size(in.)	Dim.(mm)				Wt.(Kg)		
	d	L		H	D	900lb/1500lb	2500lb
Conv.		900lb/1500lb	2500lb				
1/2	9.5	140	186	321	160	11.5	12.3
3/4	12.7	140	186	321	160	10.8	11.6
1	15.9	140	186	321	180	10.5	10.8
1 1/4	22.2	178	232	380	200	18.0	21.8
1 1/2	27	178	232	414	250	21.0	28.4
2	34.9	216	279	502	280	44.0	55.4

Dimensions & Weights (BW)

Size(in.)	Dim.(mm)				Wt.(Kg)		
	d	L		H	D	900lb/1500lb	2500lb
Conv.		900lb/1500lb	2500lb				
1/2	9.5	216	264	332	180	11.5	13.0
3/4	12.7	229	273	332	180	11.2	12.7
1	15.9	254	308	332	180	10.8	12.5
1 1/4	22.2	279	349	378	200	19.6	26.0
1 1/2	27	305	384	414	250	22.0	29.3
2	34.9	368	451	495	300	55.4	60.0