

### Construction Features

- Bolted bonnet or welded bonnet
- OS&Y
- Threaded ends or socket welding ends
- Rising stem
- Rolled-in seat ring

### Standards

- Threaded ends: ASME B1.20.1
- Socket welding ends: ASME B16.11
- Basic design: API 602
- Inspection and test: API 598

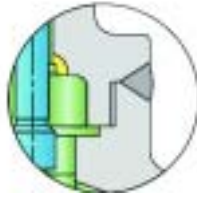

Welded Bonnet (WB)

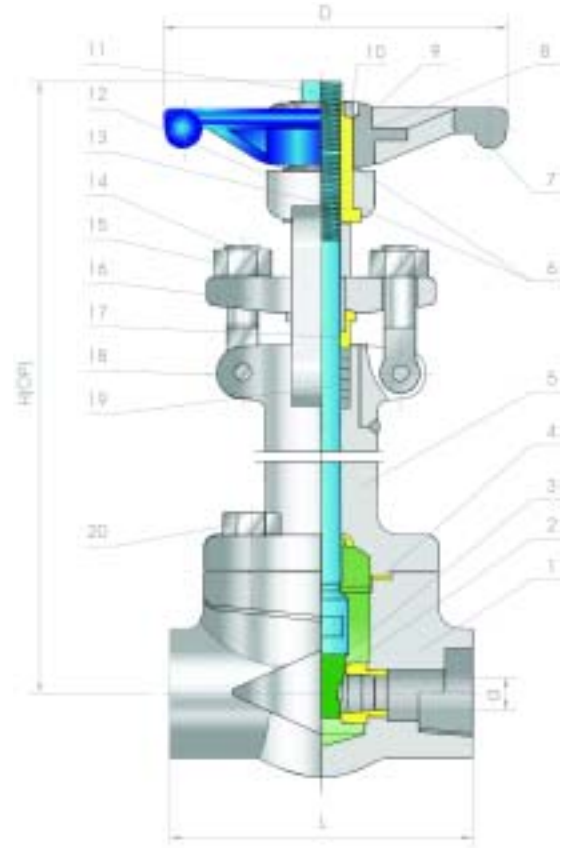

### Parts List

No.	Part Name	Material
1	Body	ASTM A182 F304
2	Seat Ring	A276-304/Stellite Overlay
3	Wedge	ASTM A276 304
4	Gasket	304SS Spiral Wound W/Graphite
5	Bonnet	ASTM A182 F304
6	Washer	ASTM A276 304
7	Handwheel	Malleable Iron
8	Nameplate	Aluminum
9	H.W. Lock Nut	ASTM A108 1020
10	Bolt	ASTM A108 1020
11	Stem	ASTM A182 F304
12	Yoke	ASTM A182 F304
13	Stem Nut	Aluminum Bronze
14	Eyebolt	ASTM A276 304
15	Eyebolt Nut	ASTM A194 Gr.8
16	Gland Flange	ASTM A182 F304
17	Gland	ASTM A276 304
18	Eyebolt Pin	ASTM A276 304
19	Packing	Graphite
20	Bolt	ASTM A193 Gr.B8

- Body material available in LF2, LF3, F316, F304L, F316L

### Dimensions & Weights

Size(in.)		Dim.(mm)				Wt.(Kg)	
Conv.	Full	d	L	H	D	BB	WB
3/8		6.4	79	298	100	4.5	4.2
1/2	3/8	9.5	79	330	100	5.2	4.8
3/4	1/2	12.7	92	333	100	7.1	6.4
1	3/4	17.5	111	360	125	9.4	8.7
1 1/4	1	23.8	120	407	160	13.5	12.2
1 1/2	1 1/4	28.6	120	475	160	15.0	13.4
2	1 1/2	36.5	140	475	180	17.8	15.2
	2	46.5	178	551	200	28.0	26.0

### Construction Features

Bolted bonnet or welded bonnet  
OS&Y  
Threaded ends or socket welding ends  
Rising stem  
Integral HF seat

### Standards

Threaded ends: ASME B1.20.1  
Socket welding ends: ASME B16.11  
Basic design: API 602、BS 5352  
Inspection and test: API 598



Welded Bonnet (WB)

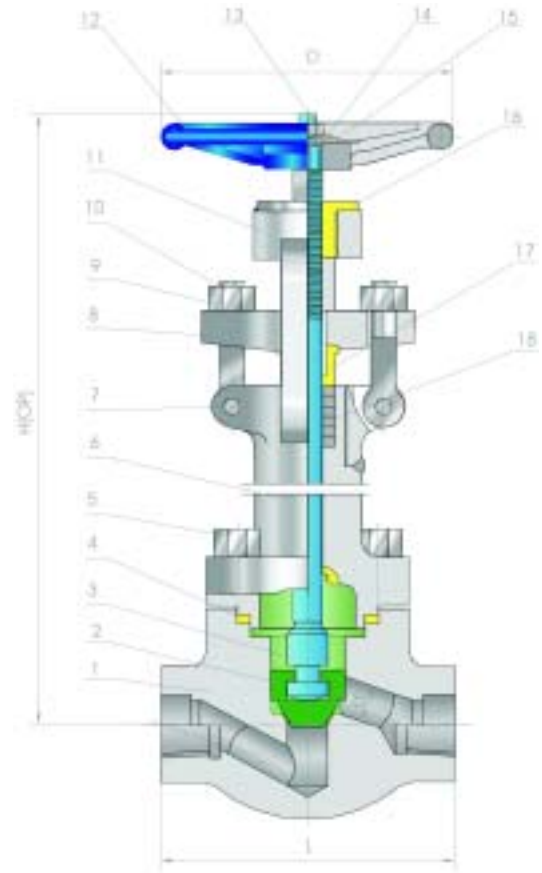

### Parts List

No.	Part Name	Material
1	Body	A182 F304/Stellite Overlay
2	Disc	ASTM A276 304
3	Stem	ASTM A276 304
4	Gasket	304SS Spiral Wound W/Graphite
5	Bolt	ASTM A193 Gr.B8
6	Bonnet	ASTM A182 F304
7	Eye Pin	ASTM A276 304
8	Gland Flange	ASTM A182 F304
9	Eyebolt Nut	ASTM A194 Gr.8
10	Eyebolt	ASTM A276 304
11	Yoke	ASTM A182 F304
12	Handwheel	Malleable Iron
13	H.W. Lock Nut	ASTM A108 1020
14	Washer	ASTM A276 304
15	Nameplate	Aluminum
16	Stem Nut	Aluminum Bronze
17	Gland	ASTM A276 304
18	Packing	Graphite

● Body material available in LF2、LF3、F316、F304L、F316L

### Dimensions & Weights

Size(in.)		Dim.(mm)				Wt.(Kg)	
Conv.	Std.	d	L	H	D	BB	WB
3/8		6.0	79	308	100	4.8	4.2
1/2	3/8	9.0	79	333	100	5.2	4.8
3/4	1/2	12.0	92	337	100	7.2	6.5
1	3/4	17.5	111	370	125	10.9	9.5
1 1/4	1	22.5	120	410	160	13.5	11.5
1 1/2	1 1/4	29.5	152	474	160	15.2	13.1
2	1 1/2	35.0	172	480	180	19.8	17.5
	2	45.5	200	546	200	29.0	26.8