

### Construction Features

- Bolted bonnet or welded bonnet
- OS&Y
- Threaded ends or socket welding ends
- Rising stem
- Rolled-in seat ring

### Standards

- Threaded ends: ASME B1.20.1
- Socket welding ends: ASME B16.11
- Basic design: API 602
- Inspection and test: API 598



Welded Bonnet (WB)

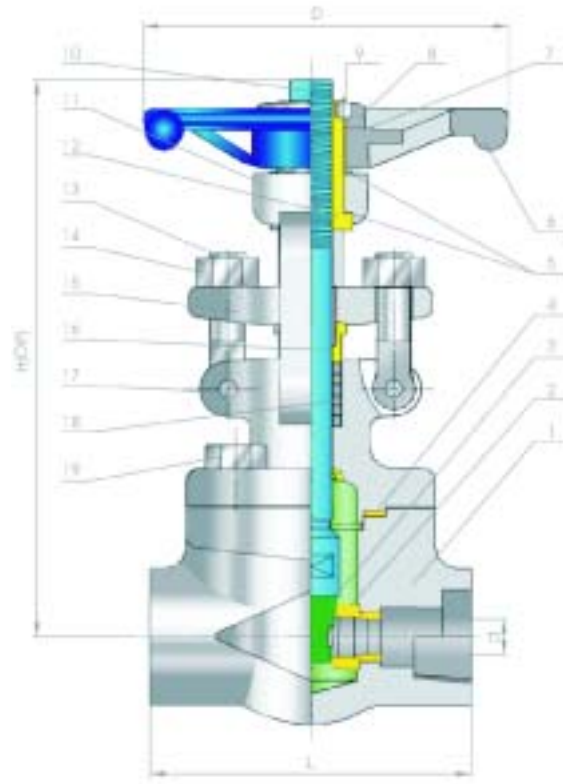

### Parts List

No.	Parts	Material
1	Body	ASTM A105N
2	Seat Ring	A276 410/Stellite Overlay
3	Wedge	ASTM A276 420
4	Gasket	304SS Spiral Wound w/Graphite
5	Washer	ASTM A276 420
6	Handwhell	Malleable Iron
7	Nameplate	Aluminum
8	H.W. Lock Nut	ASTM A108 1020
9	Bolt	ASTM A108 1020
10	Stem	ASTM A182 F6a
11	Bonnet	ASTM A105N
12	Stem Nut	Aluminum Bronze
13	Eyebolt	ASTM A276 410
14	Eyebolt Nut	ASTM A194 Gr.2H
15	Gland Flange	ASTM A105N
16	Gland	ASTM A276 410
17	Eyebolt Pin	ASTM A276 410
18	Packing	Graphite
19	Bolt	ASTM A193 Gr.B7

- Body material available in F304, F316, F304L, F316L, LF2, F11, F22, F5

### Dimensions & Weights

Size(in.)		Dim.(mm)				Wt.(Kg)	
Conv.	Full	d	L	H	D	BB	WB
3/8		6.4	92	169	100	2.5	2.4
1/2	3/8	9.5	111	197	125	4.3	4.2
3/4	1/2	12.7	111	197	125	4.2	4.0
1	3/4	15.9	120	236	160	6.6	6.3
1 1/4	1	22.2	120	246	160	8.8	8.7
1 1/2	1 1/4	27	140	283	180	12.5	12.1
2	1 1/2	34.9	178	330	200	17.2	17.2
	2	38.1	210	354	240	23.5	22.0

### Construction Features

- Bolted bonnet or welded bonnet
- OS&Y
- Threaded ends or socket welding ends
- Rising stem
- Integral HF seat

### Standards

- Threaded ends: ASME B1.20.1
- Socket welding ends: ASME B16.11
- Basic design: API 602、BS 5352
- Inspection and test: API 598



Welded Bonnet (WB)

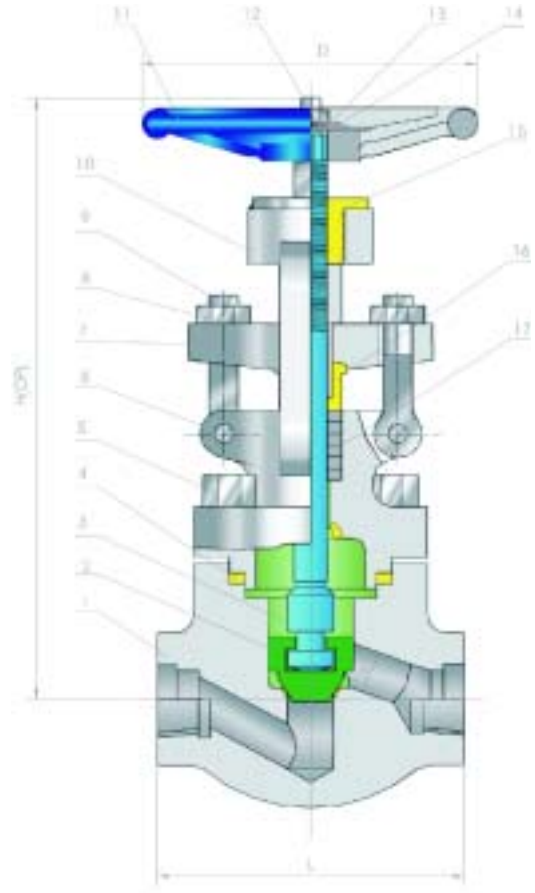

### Parts List

No.	Part Name	Material
1	Body	ASTM A105N/Stellite Overly
2	Disc	ASTM A276 420
3	Stem	ASTM A182 F6a
4	Gasket	304SS Spiral Wound W/Graphite
5	Bolt	ASTM A193 Gr.B7
6	Eye Pin	ASTM A276 410
7	Gland Flange	ASTM A105N
8	Eyebolt Nut	ASTM A194 Gr.2H
9	Eyebolt	ASTM A276 410
10	Bonnet	ASTM A105N
11	Handwheel	Malleable Iron
12	H.W. Lock Nut	ASTM A108 1020
13	Washer	ASTM A276 420
14	Nameplate	Aluminum
15	Stem Nut	Aluminum Bronze
16	Gland	ASTM A276 410
17	Packing	Graphite

- Body material available in F304、F316、F304L、F316L、LF2、F11、F22、F5

### Dimensions & Weights

Size(in.)		Dim.(mm)				Wt.(Kg)	
Conv.	Std.	d	L	H	D	BB	WB
1/2	3/8	10.0	111	207	180	3.7	3.4
3/4	1/2	13.0	111	207	180	3.6	3.3
1	3/4	17.0	120	240	180	6.8	6.0
1 1/4	1	23.0	152	258	200	7.6	5.6
1 1/2	1 1/4	30.0	172	330	250	11.6	10.3
2	1 1/2	38.0	200	355	300	15.0	14.2