



Forged Steel Pressure Seal Piston Check Valves

Class 900/1500/2500

Construction Features

- Pressure-seal Cover
- Socket welding ends and butt-welding ends
- Piston type disc
- Integral HF seat

Standards

- Socket welding ends: ASME B16.11
- Butt-welding ends: ASME B16.25
- Basic Design: ASME B16.34 、 API602、 BS 5352
- Inspection and test: API 598



Butt-Welding Ends (BW)

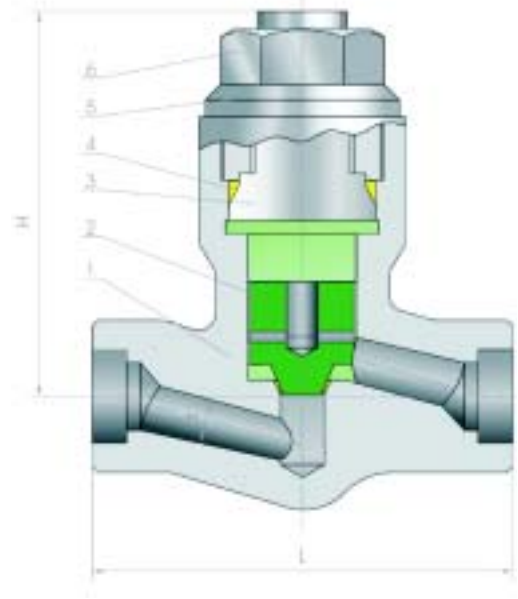

Parts List

No.	Part Name	Material
1	Body	ASTM A105N/Stellite Overlay
2	Disc	ASTM A276 420
3	Cover	ASTM A182 F6a
4	Pressure Ring	Soft Iron
5	Retaining Nut	ASTM A105N
6	P.S. Lock Nut	ASTM A194 Gr.2H

- Body material available in F304, F316, F304L, F316L, F11, F22, F5

Dimensions & Weights (900lb/1500lb)

Size(in.)	Dim.(mm)				Wt.(Kg)	
	Conv.	d	L		H	SW
SW			BW			
1/2	10	140	216	117	7.5	9.0
3/4	13	140	229	117	7.0	9.5
1	17.5	140	254	117	6.8	11.5
1 1/4	23	178	279	152	18.5	19.8
1 1/2	30	178	305	152	18.1	20.5
2	35	216	368	195	20.3	22.5

Dimensions & Weights (2500lb)

Size(in.)	Dim.(mm)				Wt.(Kg)	
	Conv.	d	L		H	SW
SW			BW			
1/2	10	186	264	117	9.0	10.5
3/4	13	186	273	117	8.6	10.8
1	17.5	186	308	117	8.4	12.5
1 1/4	23	232	349	152	19.5	21.6
1 1/2	30	232	384	152	20.1	22.5
2	35	279	451	195	21.8	25.6